

9372-FB range

Redundant fieldbus barrier enclosures, 5/6 spur

- For For FOUNDATION™ fieldbus networks in hazardous areas
- Redundant configuration for super-high system availability
- Complete enclosure systems for up to 6 intrinsically safe spur connections
- Failure alarm direct to host control system via integrated fieldbus device
- Mount in Zone 1 (gas) or 21 (dust) with spurs connected into Zone 0
- Compatible with FISCO and Entity certified fieldbus instruments
- Ergonomic mechanical design
- Pluggable system components, without 'gas free' constraints
- Optional, integrated surge protection for trunk and spurs



(Surge protection products shown are not included as standard)

The **9372-FB Redundant Fieldbus Barriers** are field-mounted wiring hubs that create up to six intrinsically safe spur connections from a high-energy trunk, for connection to suitably certified FOUNDATION™ fieldbus H1 instruments. They may be installed in Zone 1 (gas) or Zone 21 (dust) hazardous areas, with the trunk wiring implemented using suitably protected cable and increased safety (Ex e) connection facilities.

Each enclosure system uses duplicated **Fieldbus Barrier modules** in a redundant configuration to achieve significantly higher system availability than equivalent 'simplex' units. The 9372-FB may therefore be selected for critical process applications where failure of the Fieldbus Barrier would otherwise result in unacceptable downtime or lost production. It is also ideal for use in Fieldbus Safety Instrumented Function (SIF) networks in which nuisance trips cannot be tolerated. Failure annunciation to the host control system is provided by means of an integrated FOUNDATION™ fieldbus device with Digital Input Function Block capability.

In common with conventional **Fieldbus Barriers**, each intrinsically safe spur is capable of supporting a FISCO or 'Entity' certified fieldbus device located in a Zone 0 or 1 hazardous area. The short-circuit protected spurs are galvanically isolated from the trunk and require no protective ground connection in the field.

The **9372-FB redundant fieldbus barrier is based on our revolutionary 9370-FB range of products**, which are supplied

as complete, factory-assembled enclosure systems that do not require additional wiring, customised housings or complex ancillary components. Electrical and mechanical aspects of the design are integrated, providing the industry's first complete, ergonomic solution for 'High Energy Trunk' applications in hazardous areas.

Uniquely, the key modular components of the system (Fieldbus Barrier, Terminator and Surge Protectors) may be 'hot-plugged' by design and without gas-clearance procedures or separate isolating switches. This virtually eliminates the risk associated with hazardous area maintenance activities, speeds module replacement and avoids the need for specialist operator training.

Optional features include pluggable surge protection components for the fieldbus trunk and individual spurs. Connection facilities with generous room for cable management are provided within the Fieldbus Barrier enclosure for the trunk and spur wiring.

For added flexibility, a redundant-capable enclosure can be specified part-populated with one 6-spur module (model no. 9375-FB). This permits future upgrading from simplex to redundant mode simply by plugging in an additional Fieldbus Barrier module and optional alarm module.

The **9372-FB Fieldbus Barrier is bus powered** and requires no additional power supply in the field. When used with a fieldbus host control system, power for the trunk may be provided by redundant power supplies.

SPECIFICATION

SPURS

	9372-FB* Redundant 5-spur	9375-FB* Redundant- enabled 6-spur
No. of spurs	5 (6 th spur allocated to alarm module)	6
No. of 9377-FB modules installed	2	1 (upgradable to 2)
Current per spur	0 - 32mA	0 - 32mA
Total current all spurs (max.)	160mA	192mA
Current limit per spur (max.)	45mA	
Spur short-circuit current (max.)	4.5mA	
Spur voltage @ 20°C	≥ 10V @ 40mA	
No-load voltage	12V min.	
Number of field devices	1 per spur	
Maximum spur length	120m (depending on the number of spurs per fieldbus segment)	
Galvanic isolation (to EN 60079-11)	Trunk to spurs: 1.5kV (test voltage) Spur to spur: no isolation	
Spur surge protection	Plug-in module (part number FS32) - see separate specification	

TRUNK

Data rate	31.25kbaud
Data transmission between trunk and spurs	passive, no repeater function
Number of trunk connections	2 (in & out), internally connected
Maximum number of 9377-FB-R modules per segment	2 redundant pairs (total 10 spurs**)
Input voltage range (trunk)	16–32V DC
Voltage drop (trunk in to trunk out)	0V
Maximum rated current (trunk in to trunk out)	5A
Low voltage monitoring	Input voltage < 16V, spurs de-energized
Typical DC current consumption for 9372-FB (mA)	

		@ 16V	@ 24V	@ 32V
No load on each spur	typ.	77.9	62.9	49.6
	max.	80.0	65.0	51.0
1 spur @ 20mA	typ.	102.8	81.1	64.3
	max.	120.0	84.0	80.6
All spurs @ 20mA	typ.	201.7	144.1	114.2
	max.	208.0	149.0	118.0
All spurs @ 20mA 1 short-circuit	typ.	185.0	135.6	106.5
	max.	191.0	140.0	110.0
All spurs @ 32mA	typ.	276.5	191.9	149.4
	max.	288.0	198.0	154.0

Power dissipation (max.)

2.5W (all spurs at 32mA)

Fieldbus terminator

Plug-in module (part number 9378-FT) supplied with each 9372-FB or 9375-FB enclosure.

Provides 100Ω + 1μF according to IEC 61158-2 - see separate specification

Trunk surge protection

Plug-in module (part number 9376-SP) - see separate specification

Reverse polarity protection

Yes

Failure alarm

Failure of either 9377-FB-R barrier module in redundant mode is annunciated over FOUNDATION™ fieldbus via state change of DI Function Block in 9379-ALM alarm module (standard in 9372-FB enclosure)

ELECTRICAL CONNECTIONS

Trunk wiring terminals

Type: Ex e

Cable types and capacity	Screw cage clamp - mm ²	Spring cage clamp - mm ²
Rigid cable	0.5 to 4.0	0.5 to 4.0
Flexible cable	0.5 to 2.5	0.5 to 2.5

Spur field wiring terminals

Type: 3-way, pluggable

Cable types and capacity	Screw cage clamp - mm ²	Spring cage clamp - mm ²
Rigid cable	0.2 to 2.5	0.2 to 2.5
Flexible cable	0.25 to 2.5	0.25 to 2.5

Grounding of cable screens (trunk & spurs)

(Configured with wire connections in the Trunk Terminal Assembly)

Options	Trunk	Spurs
1 Single point grounding	Grounded at host	Trunk & spur screens joined
2 Local grounding of spurs	Grounded at host	Grounded at field enclosure

Trunk and spur cable shields are not interconnected within 9377-FB-R module.

Equipotential earth/ground connection facility

M10 earth/grounding stud on side wall of enclosure

BARRIER LED INDICATORS

Trunk Power (PWR)

	ON	OFF
Green	Supply voltage > 16V, internal supply healthy	Supply voltage < 16V or no supply

* See ordering information

** 9372-FB supports 5 spurs, 9375-FB supports 5 spurs when alarm module is fitted or 6 spurs, when alarm module not fitted. Total of 12 spurs supported for 2 x 9375-FB with no alarm module fitted.

*** The FF-846 Isolated Device Coupler registration does not include tests for hardware redundancy. Although operation of the redundancy mechanism has been thoroughly tested, registration of the redundant capability is not implied by the application of the Foundation's checkmark.

HAZARDOUS AREA APPROVALS

Location of equipment

Safe area or Zone 1 IIC T4 or Zone 21 hazardous area

Location of connected spur equipment

Safe area or Zone 0 IIC hazardous area

Certification marking

Ex II 2(1)GD Ex d e ib mb [ia Ga] IIC T4 Gb
Ex tb IIIC T80°C Db

Certificate numbers

Baseefa09ATEX0185X
IECEX BAS09.0082X

Safety description (spurs)

U_o = 17.5V
I_{o peak} = 246mA
I_{o continuous} = 215mA
P_o = 912mW
U_i = 17.5V
C_i = 0
L_i = 0

Spurs in accordance with FISCO standard IEC 60079-11

ENVIRONMENTAL

Ambient temperature (system)

PP-System	SS-System	Storage (PP or SS)
-40°C to +65°C	-40°C to +70°C	-40°C to +75°C

Ambient temperature (9377-FB-R module)

-40°C to +75°C

Relative humidity

< 95%, non-condensing

Electromagnetic compatibility

EN 61326-1:2006
NAMUR NE 21

Shock & Vibration

Vibration:

BS EN 60068-2-6: 2008 Test Fc: 1g
BS EN 60068-2-64: 1995 Test Fh: 1g

Shock:

BS EN 60068-2-27: 1993 Test Ea: 15g

MECHANICAL

Materials

937x-FB-xx-SS*	937x-FB-xx-PP*
316L Stainless Steel	Black, Glass Reinforced Plastic (GRP)

* See ordering information

Enclosure sizes - see dimension drawings for details

GRP, 5 spurs** 554 x 271x 136mm
Stainless steel, 5 spurs** 428 x 271x 130mm

** See footnote on page 2

Mounting position (recommended)

On vertical plane, with glands and breather on underside

Cable/Breather entries

Trunk: M20 x 2; Spurs: M20 x 6 Breather: M20 x 1

Enclosures are pre-fitted with a breather and Ex e nickel-plated brass plugs in all cable gland holes. These must be replaced only with Ex e equipment certified cable glands capable of maintaining the IP level of the enclosure type. See ordering information for gland options.

Protection

Stainless steel enclosures (937x-FB-xx-SS): IP66
GRP enclosures (937x-FB-xx-PP): IP66
Intrinsically safe terminals : IP20
Ex e terminals: IP30

PHYSICAL NETWORKS

IEC61158-2

FOUNDATION™ fieldbus H1

Profile type (according to FF-816)

Type 163 (isolated device coupler) FF-846***

ORDERING INFORMATION

Order as:

9372-FB-xx-XX 5-spur Redundant Fieldbus Barrier enclosure system with two 9377-FB-R Fieldbus Barrier modules and one 9379-ALM alarm module installed.

9375-FB-xx-XX 5/6-spur Fieldbus Barrier enclosure system with one 9377-FB-R Fieldbus Barrier module installed. (Upgradable to redundant operation by addition of a second 9377-FB-R module and optional 9379-ALM alarm module).

Where **xx** = PS (pluggable screw terminal connectors) PC (pluggable spring clamp connectors)

Where **XX** = SS – 316L Stainless Steel
PP – Glass Reinforced Plastic (GRP) - Black

(Note: All enclosures are pre-wired and include a 9378-FT Fieldbus terminator module)

9377-FB-R Fieldbus Barrier module, 6-spur, pluggable

9379-ALM Alarm module

9378-FT Fieldbus terminator, pluggable

9376-SP Trunk surge protection module, pluggable

FS32 Spur surge protection module, pluggable

CABLE GLANDS

The following M20 cable glands are Ex e equipment certified, better than IP65 rated and suitable for use with the 9370-FB range of Fieldbus Barriers. They can be supplied separately and are available to order using the following part numbers.

Order No.	Manufacturer and Type	Description (Qty 1)
FCS-1000-P20	Jacob 50.620 PASWL/Ex	Plastic gland
FCS-1000-C20	Capri 816694	Nickel-plated brass gland
FCS-1000-A20	Capri 846694	Armoured nickel-plated brass gland
FCS-1000-S20	Capri 816699	Stainless steel gland
FCS-1000-R20	Capri 846699	Armoured stainless steel gland

ASSOCIATED LITERATURE

Instruction Manual - GRP enclosures

Instruction Manual - stainless steel enclosures

INM9370-RD-PP

INM9370-RD-SS

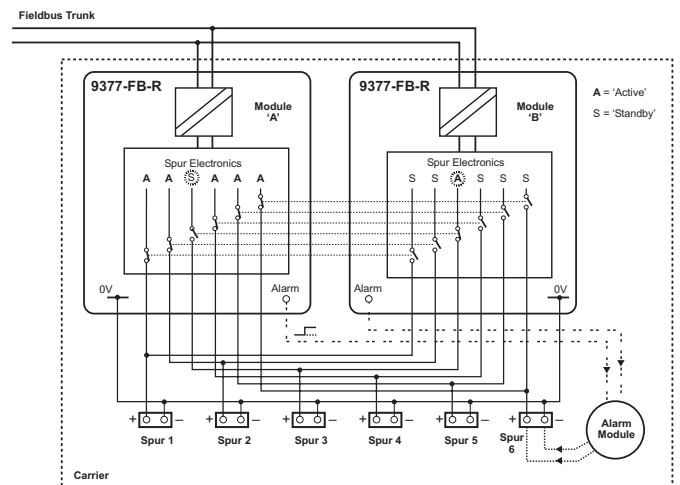

Figure 1 - Illustrating spur redundancy and use of optional Alarm module

9372-FB range

November 2016

DIMENSIONS (mm)

Stainless Steel Enclosure
Mounting holes: \varnothing 10.8mm

9372-FB-xx-SS
9375-FB-xx-SS

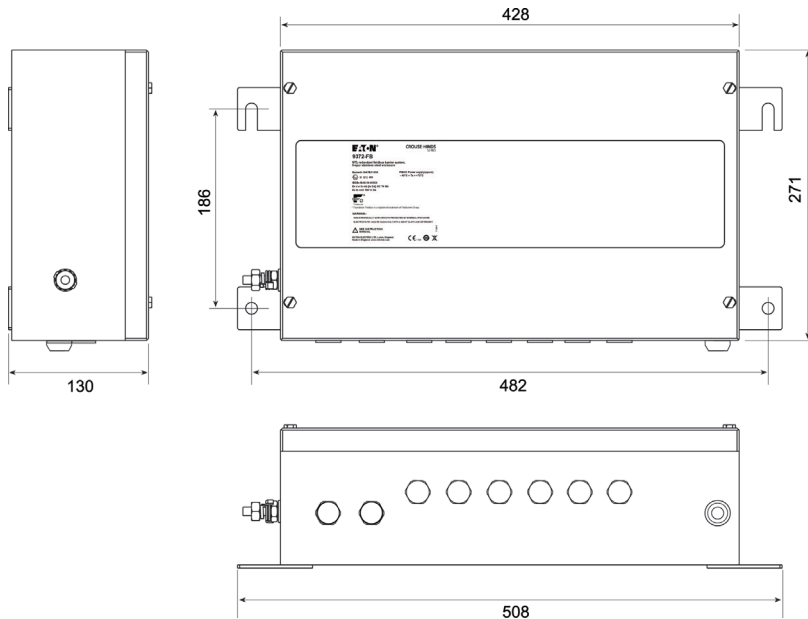

GRP Enclosure
Mounting holes: 6.5mm slot,
12mm head max.

9372-FB-xx-PP
9375-FB-xx-PP

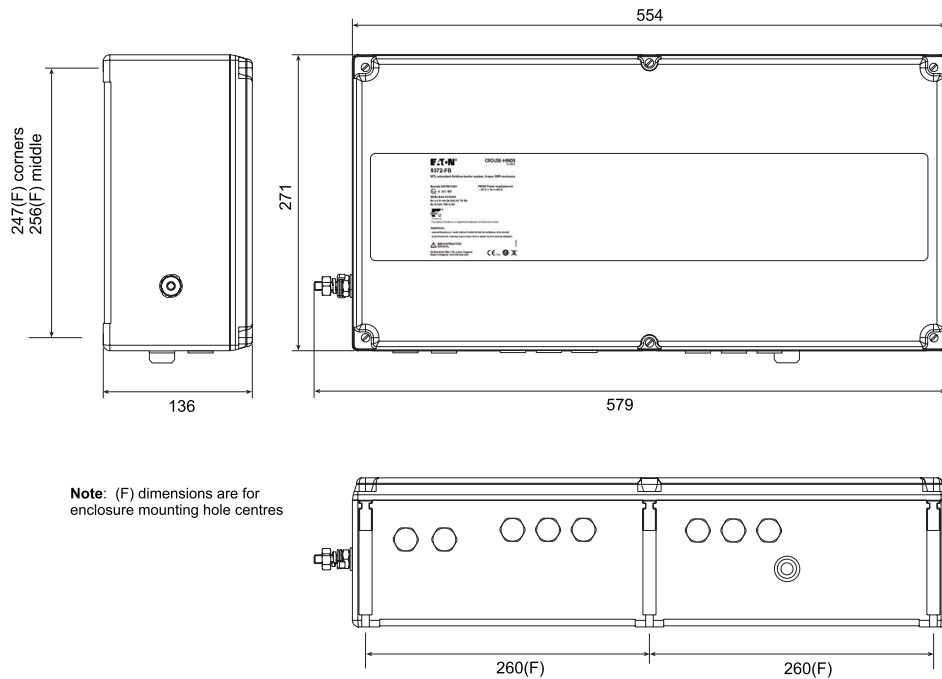

Note: (F) dimensions are for enclosure mounting hole centres



Eaton Electric Limited,
Great Marlings, Butterfield, Luton
Beds, LU2 8DL, UK.
Tel: + 44 (0)1582 723633 Fax: + 44 (0)1582 422283
E-mail: mtlenquiry@eaton.com
www.mtl-inst.com

© 2016 Eaton
All Rights Reserved
Publication No. EPS9372-RD Rev 6
November 2016

EUROPE (EMEA):
+44 (0)1582 723633
mtlenquiry@eaton.com

THE AMERICAS:
+1 800 835 7075
mtl-us-info@eaton.com

ASIA-PACIFIC:
+65 6 645 9888
sales.mtlsing@eaton.com

The given data is only intended as a product description and should not be regarded as a legal warranty of properties or guarantee. In the interest of further technical developments, we reserve the right to make design changes.